

# SERVICE MANUAL



BULLETIN NO. S375-87-R3

## MR-375 LOW SPEED HIGH TORQUE HYDRAULIC MOTOR HYDROSTAR

### INSTALLATION MOUNTING

The coupling used on the motor shaft should have a Brinell Hardness rating of 200 or more. Spline couplings are available from your distributor of HYDROSTAR motors.

Coupling (female) specifications:

- Involute spline SAEJ498b
- Taper shaft 1/10 Taper  $\pm$  42 seconds

Recommended tightening torque:

- Nut of taper shaft coupling (2-4 1/2 UNC) = 820 Ft. Lbs.
- Mounting bolts (1" Grade 5) = 500 Ft. Lbs.
- Shaft end bolts of spline shaft (5/8-18 UNF) = 150 Ft. Lbs.

The eccentricity of the shaft and the coupling should be within 0.002" TIR when the shaft is directly connected to the driven shaft.

When assembling the coupling to the motor do not use force. If difficulty is encountered, check the motor's shaft and coupling for burrs or nicks. File smooth the interference. If this doesn't solve the problem, check for size; correctly mated parts will assemble without any pressure. The pilot diameter of the mounting bracket is 17.960 / 17.956 in normal use. For applications where shocks or frequent reversal operation is anticipated the clearance of the motor pilot diameter and the mounting bracket should be within 0.003" TIR.

### PIPING

All parts inside the motor are oil lubricated, therefore it is necessary to fill the motor crank case through the highest drain port with clean oil before operating motor.

Return lines from the drain ports should be piped directly back to the tank without any restrictions. CAUTION: When motor operates with shaft up, an air bleed should be installed through the front cover to insure lubrication of the front bearing. Consult KYB for information. The typical ways for piping lines are:

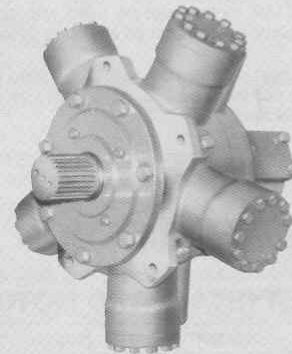
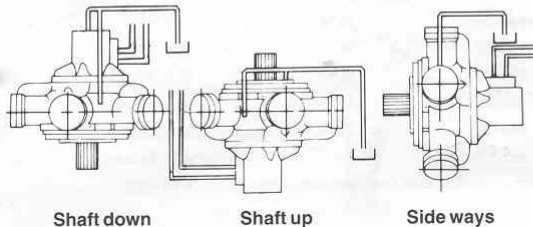

### SPECIFICATIONS

Displacement volume	374.2 IN <sup>3</sup> /REV.
Maximum continuous pressure	3000 PSI
Intermittent peak pressure	3300 PSI
Maximum continuous back pressure	350 PSI
Maximum intermittent back pressure	1000 PSI
Maximum continuous output torque	13740 FT.-LBS.
Starting Torque at 3000 PSI	11900 FT.-LBS.
Maximum continuous speed	90 RPM
Maximum continuous power	165 HP
Moment of inertia (GD <sup>2</sup> )	8085 LB.-IN. <sup>2</sup>
Maximum fluid temperature	175°F
Dry weight	1444 LBS.

Internal crank case drain pressure should not exceed 15 psi.

Use 3/4" drain pipe for this model and should not exceed 30 feet.

The oil level of the reservoir should not exceed 15 feet over the motor if the reservoir is located above. If the motor is located above the reservoir, piping should be looped higher than the motor crankcase.

### BACK PRESSURE

The motor should be operating under sufficient back pressure, though the HYDROSTAR motor can withstand limited vacuum pressure. This consideration insures smooth and safe operation and protects the whole hydraulic system from noise and vibration breakage. The required minimum back pressure is a half of idling pressure plus case pressure. (Refer to MR-375 individual catalog in detail). In any condition, the back pressure should not exceed 1000 psi intermittently or 350 psi continuously.

### FILTRATION

In most applications 100 mesh strainer and 25 micron filter is acceptable for HYDROSTAR motors. But it is advisable to determine the filtration required by the pump manufacturer because pumps are more critical against the contamination rather than motors.

## HYDRAULIC FLUID RECOMMENDATION

The fluid selected should be a good grade non-detergent mineral oil with additives added for wear resistance, anti-foam, anti-rust, anti-oxidation and extreme pressure. Minimum viscosity of the hydraulic fluid is 120 SUS. However, it is recommendable for continuous operation to maintain the viscosity between 165 and 345. Viscosity index of 100 or more is desirable.

The HYDROSTAR motors can be used with special fluids such as phosphate ester, water oil emulsion or water glycol.

If the fluid used is phosphate ester, then viton O-rings and shaft seals are required and the supplier must be made aware of this need.

For water oil emulsions and water glycol the system pressure must be restricted to 2,000 psi.

## START-UP

When the motor is required to rotate clockwise, connect the pressure line to the oil point "R", embossed on the side of valve housing. Just reverse the connections if direction changes.

Air must be completely purged from the hydraulic system otherwise the hydraulic components will be subject to failure. The HYDROSTAR motor may be purged by operating for a while under no load, removing air by venting piping at highest point. Check also that no air bubbles are present in the tank before beginning the operation.

Make sure all connections are tight.

## PARTS INFORMATION

### PART LIST (STANDARD MOTOR)

ITEM	DESCRIPTION	QUANTITY	GRADE	ITEM	DESCRIPTION	QUANTITY	GRADE
1	Motor Housing	1	C	31	Snap Ring – Valve Housing	1	D
2	Valve Housing	1	C	32	Snap Ring – Piston	5	D
3	Valve Bearing	1	C	33	Snap Ring – Crank Shaft	2	D
4	Rotary Valve	1	C	34	Hexagon Head Screw	7	D
5	Valve Seal	4	C	35	Hexagon Head Screw	55	D
6	Valve Bearing	1	C	36	Hexagon Head Screw	6	D
7	Valve End Cap	1	D	37	Socket Head Cap Screw	5	D
8S	Crank Shaft	1	C	38	Spring Washer	7	D
8T	Crank Shaft	1	C	39	Spring Washer	55	D
9	Crank Shaft Front Bearing	1	C	40	Spring Washer	6	D
10	Crank Shaft Rear Bearing	1	C	41	Spring Washer	5	D
11	Oldham Coupling	1	D	42	Drain Plug	2	D
12	Connecting Rod	5	B	43	Eye Bolt	1	D
13	Piston	5		44	Lock Bolt	1	D
14	Piston Ring	10	C	45	"O" Ring – Lock Bolt	1	A
15	Con. Rod-Piston Collar	5 Set	D	46	Lock Nut	4	D
16	Cylinder Cap	5	D	47	Set Screw	4	D
17	Con. Rod Retaining Ring	2	C	52T	Hexagon Nut	1	D
18	Front Cover	1	D	53T	Spring Washer	1	D
24	Shaft Seal	1	A	54T	Plain Washer	1	D
25	"O" Ring – Front Cover	1	A	55T	Key	1	C
26	"O" Ring – Valve Housing	1	A	62	Fastener Seal	4	A
27	"O" Ring – Valve End Cap	1	A	92	"O" Ring – Plain Plug	2	A
28	"O" Ring – Cylinder Cap	5	A	93	Drain Plug	1	D
29	"O" Ring – Inter. Oil Passage	5	A	94	"O" Ring – Drain Plug	1	A

- Notes:
- Suffix S ..... Only Spline Shaft.  
Suffix T ..... only Taper Shaft.
  - Grade A ..... These parts should be replaced whenever the motor is disassembled.  
Grade B ..... These parts should be replaced only as matching pairs and will probably need replacement during the life period of the motor.  
Grade C ..... These parts will probably need replacement during the life period of the motor.  
Grade D ..... These parts seldom if ever require to be replaced.

#### 3. Recommended Tightening Torques

Item 34	M-24	535 ± 5 Ft.-Lbs.
Item 35	M-18	175 ± 5 Ft.-Lbs.
Item 36	M-12	60 ± 3 Ft.-Lbs.
Item 37	M-27	690 ± 5 Ft.-Lbs.
Item 52T	2 UNC	820 ± 10 Ft.-Lbs.
LOCK BOLT		140 Ft.-Lbs.

- For parts other than described here, please contact KYB Corp.

### EXPLODED VIEW

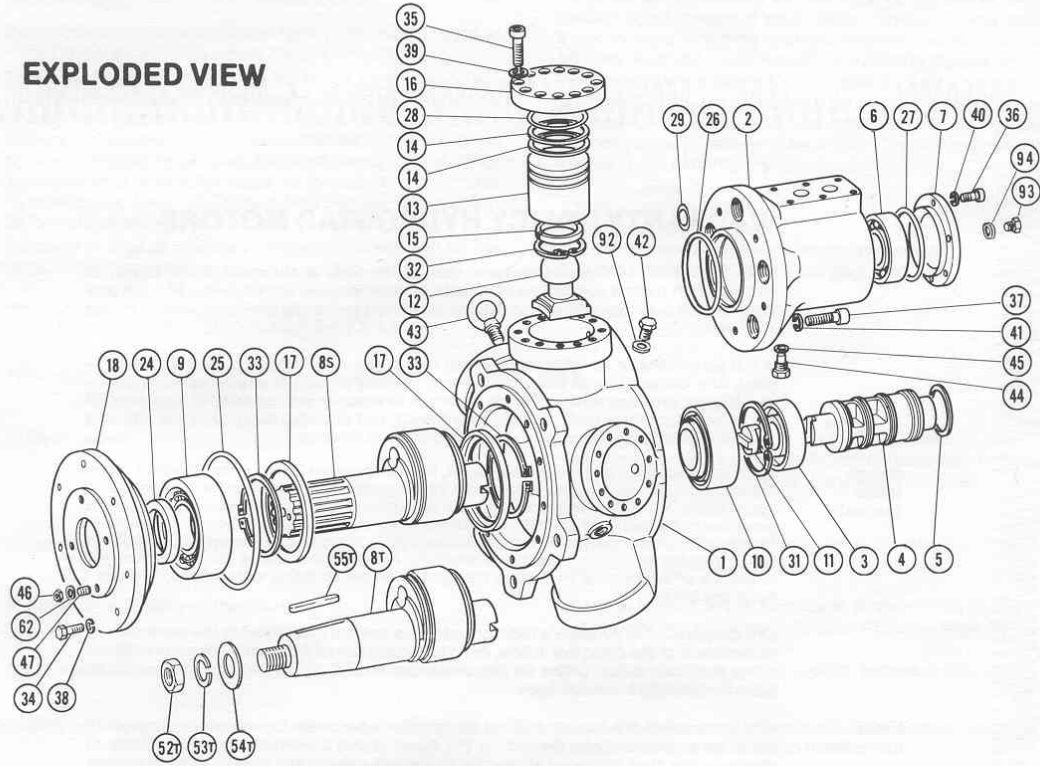

### SECTIONAL VIEW

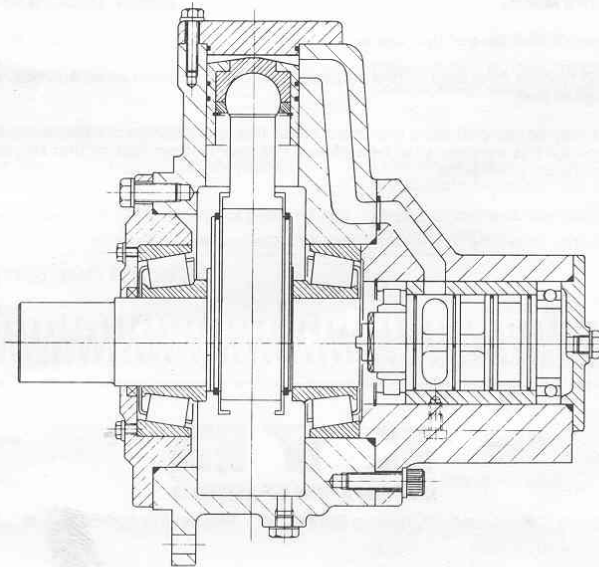

## SERVICE INFORMATION

### REPAIRING MOTORS UNDER WARRANTY

Repair work is not to be attempted by anyone other than the personnel of KYB Corporation of America unless otherwise agreed or should be entrusted to the repair shops designated by KYB Corporation of America.

The claims under warranty can not be entertained if the motor in question is repaired by the customer.

### PREPARATION

Before removing the motor from the installation, drain all oil within, then cover the oil port area to prevent foreign particles from entering the motor. Before disassembling the motor, clean outside of the motor thoroughly by washing with clean solvent.

### DISASSEMBLY PROCEDURE

1. Front Cover
  - (a) Position the motor shaft up and remove the Socket Head Cap Screws (34), using an Allen wrench. Insert two jacking screws (M12P1.75) in the tapped holes of the Front Cover (18), then evenly retract the front cover. At this time, pay attention not to damage the shaft and the shaft seal.
  - (b) Remove the Lock Nut (46), Set Screws (47) and the Fastener Seal (62) from the Front Cover (18). Remove the O-ring (25), the Shaft Seal (24) and the outer cup of the Front Bearing (9).
2. Cylinder Cap
  - (a) Remove the Socket Head Cap Screws (35) on each Cylinder Cap (16).
  - (b) Using a screw driver, remove the cylinder caps from the Motor Housing (1). Check to be sure no damage occurred to the O-rings (28) underneath the cylinder caps.
3. Crank Shaft
  - (a) Using snap ring pliers, remove the Front Snap Ring (33). Lift the Connecting Rods (12) clear of the Rear Retaining Ring (17).
  - (b) Lift out the Crank Shaft (8) then remove the Oldham Coupling (11). Use snap ring pliers to remove the Rear Snap Ring (33) and the Rear Retaining Ring (17).
  - (c) use a hammer and brass bar rod to remove the Bearings (9), (10) from the crank shaft.
  - (d) Care must be taken during the process not to damage the machined surfaces of the crank shaft and connecting rods.
4. Connecting Rod and Piston Assembly
  - (a) Remove the Piston Assembly (12) (13) (14) (15) (32) from the motor housing by pulling the Pistons (13) toward the piston cap.
  - (b) Position the Piston Assembly, Connecting Rod (12) up and use snap ring pliers to remove the Snap Ring (32). Remove the two Con. Rod-Piston Collars (15) and pull the connecting rod away from the Piston (13).
  - (c) use piston ring expander to remove the Piston Rings (14) from piston.
5. Valve Housing.
  - (a) Position the motor so that the Valve Housing (2) is up. Be sure not to damage the machined surface on the bottom side.

- (b) Use Allen wrench to remove the Socket Head Cap Screws (37).
- (c) Insert two jacking screws in the tapped holes of the valve housing and remove it from the motor housing.
- (d) Use Allen wrench to remove the Socket Head Cap Screws (36) and remove the Valve End Cap (7) from the valve housing, then press the Rotary Valve (4) out from the valve housing toward the valve end cap. Valve Seals (5) of the rotary valve can be easily removed, using the piston ring expander.
- (e) use the snap ring pliers to remove the Snap Ring (31) and press the outer cup of the Bearing (6) out from the Valve Housing (2).

### ASSEMBLY PROCEDURE

1. Valve Housing

Insert the Valve Seals (5) into the grooves for the Rotary Valve (4) and press the valve into the Valve Housing (2) from valve end cap side. The outer cup of the Roller Bearing (3) is pressed in the valve housing and held by Snap Ring (31). Press the Valve Bearing (6) into the valve housing. Place the O-ring (27) into the recess in the face of the Valve End Cap (7) and install on the valve housing. Place the O-rings (26) (29) in the face of the Valve Housing (2), install onto the Motor Housing (1).
2. Connecting Rod and Piston Assembly

Place the Piston Rings (14) into the grooves of the Piston (13). Reverse the steps in 4 of the disassembly procedure in order to reassemble the Piston Assembly. Then insert it from outside of the motor housing.
3. Crank Shaft

Press the outer cup of the Bearing (10) into the Motor Housing (1) and the inner races of the bearings onto the Crank Shaft (8). Place the Oldham Coupling (11) on the rotary valve with surface "L" stamped up. Position the Rear Retaining Ring (17) into the groove of the crank shaft cam with the Rear Snap Ring (33) and insert the Crank Shaft (8) into the motor housing. Make sure to line the "L" stamped on the rotary valve and the oldham coupling with the center of the crank shaft cam.

Position the connecting rods onto the crank shaft cam and retain them by the Front Retaining Ring (17) and the Front Snap Ring (33).
4. Front Cover

Press the outer cup of the Front Bearing (9) and the Shaft Seal (24) into the Front Cover (18). Insert the O-ring (25) and install the front cover to the motor housing.

Tighten evenly the 4 Set Screws (47) against the outer cup of the Front Bearing (9) until the moment of the crank shaft becomes 47 to 51 ft-lbs. Lock the set screws with Fastener Seals (62) and Lock Nut (46) to prevent the set screws from loosening.
5. Cylinder Cap

Cover Cylinder Caps (16) on each cylinder bore. Make sure not to damage O-ring (28) when assembling.

## RETURNING OF MOTORS UNDER WARRANTY FOR REPAIR

All motors or parts which have failed and are returned to KYB Corporation must arrive freight prepaid.

The repairing of HYDROSTAR motors or parts that failed, must be done by KYB Corporation of America or repair shops designated acceptable by KYB Corporation. Claims for warranty will not be accepted if repair is done by the customer or an unauthorized repair center. Prior arrangements should be made for the return of the motor by contacting the KYB Corporation Service Department before shipment is made by the customer.

Damage or loss of returned articles in transit will be the responsibility of the buyer.

Motors or parts deemed defective and returned for warranty consideration or repair to KYB Corporation must be accompanied by the buyers purchase order (and/or debit memo) if applicable. The purchase order must include shipping instructions and accompany all articles returned, even though in-warranty repairs will be performed at no charge to the buyer.

It is the buyers responsibility to assure that sufficient information accompanies the returned motor to enable warranty determination to be made. The following information must accompany each unit returned.

1. Customer
2. Date of retail sale
3. Date of unit failure
4. Motor model number and serial number
5. Reason for return or rejection

## TROUBLE SHOOTING

### Motor will not turn on, operates erratically

Cause	Solution
1. Overloaded	Reduce the load, or if there is a pressure control, increase the pressure as much as acceptable with factory. Consult the local distributor if either action does not correct the situation.
2. Insufficient system pressure across the motor port.	Check pump and/or relief valve for deterioration. Check to see if there is any passage open to tank.
3. Crank shaft loose in the bearing.	Adjust set screws on the front cover so movement of crank shaft is matched with specific torque. (Refer to page 4).
4. Oil viscosity is too high or too low.	Check the oil viscosity and system temperature. (Refer to page 2).
5. Stall when starting or during at low speed operation.	Adjust the relief valve in the system to increase the pressure enough for shaft to turn.
6. Shaft coupling defective.	Adjust or replace if necessary.
7. Oldham coupling broken.	Replace the coupling.

### Motor falls off under load

Cause	Solution
1. Insufficient oil inflow	Check pump output, incorrect speed of primary power and for relief valve leakage. Correct any failures.
2. Excessive oil leakage inside the motor. a. Oil viscosity too low and/or high oil temperature. b. Wear or damage in the rotary valve, piston or piston rings.	Operate at lower temperature or replace with fluid having a viscosity between 165 and 345 SUS. Repair or replace the damaged and worn parts. (Refer to page 4).

### Direction of rotation reverse

Cause	Solution
1. Piping reverse	Correct by reverse plumbing to ports. Disassemble, reverse valve to correct the positioning.

### Oil Leakage

Cause	Solution
1. Shaft seal damaged.	Replace the shaft seal.
2. Reversal of shaft seal lip.	Check crank case pressure and increase of drain port plumbing if less than port opening. (Refer to page 1).

## WARRANTY POLICY HYDROSTAR MOTORS

<b>Warranty</b>	<p>KYB Corporation of America warrants that, at the time of shipment to the Buyer, all HYDROSTAR motors will be free of defects in materials and workmanship and will conform to such drawings and specifications as defined by the purchase agreement of said shipment.</p> <p>In full settlement of its obligations under this or any other warranty expressed, or implied, KYB Corporation of America agrees to replace or correct any defective article or part thereof provided notice of such defect is received in writing prior to expiration of the "Warranty time period" as described herein, and provided such defective article is made available for inspection by KYB Corporation of America.</p>
<b>Return Under Warranty</b>	<p>At KYB Corporation of America's request, it is the responsibility of the Buyer to return the defective article freight prepaid to KYB Corporation of America for inspection. If upon inspection said article is found to be defective, it shall be replaced, repaired or the purchase price refunded at KYB Corporation of America's option. Should the article be found defective in material or workmanship, KYB Corporation of America will credit the buyer for prepaid freight incurred in returning the defective article for inspection, and return the article prepaid by surface transportation per shipping instructions on Buyer's purchase order.</p> <p>KYB Corporation of America's liability under this warranty is limited to the correction or replacement of the defective article, or KYB Corporation of America's option to a refund of the purchase price. Under no circumstances shall KYB Corporation of America be liable for consequential damages.</p>
<b>Labor Exclusion</b>	<p>KYB Corporation of America shall not be liable for labor costs for removal or reinstalling defective articles or parts thereof. If the Buyer grants a warranty on such articles of greater scope than indicated above, the Buyer will assume the burden of such greater warranty and hold KYB Corporation of America harmless from any claims of third parties based upon such extended warranty.</p>

### WARRANTY TIME LIMITATIONS

#### I. All HYDROSTAR Models

- (1) Six (6) months from date of first use or
- (2) Twelve (12) months from date of first shipment from KYB Corporation of America, whichever period expires first.
- (3) An article may be repaired more than once under this warranty, but the maximum cumulative time period for this warranty shall be eighteen (18) months from date of first shipment from KYB Corporation of America.

#### II. Service Parts

- (1) Six (6) months from date of shipment from KYB Corporation of America.